

HHT01 Handheld speed test recorder user's manual



SIBO.X INDUSTRIAL CO.,LTD.

Add: No. Building 1, No. 1, Jingshi Road, Cicheng Town Industrial Park,
Jiangbei District, Ningbo City, Zhejiang, China

<https://www.sbxsun.com>

Email: info@sbxsun.com

Tel: +86-15958288207

Table of contents

1.product description	1
1.1product description	1
1.2Features	1
1.3 technical parameter	1
1.4product model	2
2.Dimensions	2
3.Instructions	2
3.1 Equipment List	2
3.2 Structure description	2
3.3Sensor connection device	3
4.Function and operation instructions	3
4.1Key Description	3
4.2Main interface introduction	5
4.3Instructions	6
5. Configuration software instructions	8
5.1 Device Information	8
5.2 Basic Information	9
5.3Channel parameters	10
5.4Import Data	11
5.5export data	12
5.6Clear device data	12
6.Description of charging function	13
7.Precautions	13
8.Common faults and solutions	13

1.product description

1.1product description

The handheld speed test recorder developed and designed by our company adopts the latest digital integrated circuit technology and international testing technology to design a brand-new intelligent handheld detector. The recorder adopts a large-size full-color LCD screen, which can display readings in real time. At the same time, it uses a detection circuit designed by digital chips from international manufacturers, which can achieve very high sensitivity and excellent repeatability. It integrates storage, recording and analysis. The standard Modbus-RTU communication mode can be used to flexibly access various 485 devices. Up to 32 channels can be preset, and up to 32 elements can be collected. The recorder is widely used in the detection of soil pH, dry farming, water-saving irrigation, precision agriculture, forestry, geological exploration, plant cultivation, water conservancy, environmental protection and other fields and the measurement of the pH of various particulate matter.

1.2Features

- 1) The measurement results can be displayed directly, which is simple and convenient, with low measurement cost and fast measurement speed.
- 2) Large size color display screen, beautiful interface.
- 3) One-click data export, convenient and fast.
- 4) Free access to 485 devices
- 5) Large storage space, can store up to 34w pieces of data
- 6) Over-limit alarm, various prompts

1.3 technical parameter

Power supply	Battery powered (5000mAh lithium battery)
Display method	2.8 inch LCD screen
data storage	34W pieces of data
charging time	≤8h
working environment	Temperature -20℃-60℃; humidity <95%RH without condensation
Accessible equipment	1-4 ModBus device combinations
letter of agreement	Modbus-RTU protocol
Operating Voltage	DC 3.7V
Standby time	More than 8h continuous
size	174*88.5*35mm
weight	284g

1.4 product model

RS-				company code	
	HHT-				Handheld speed test recorder
		N01-			485 communication
			2-		case
				USB	USB data export
				BT	Bluetooth printing (not yet developed)
				4G	4G upload (not yet developed)

2. Dimensions

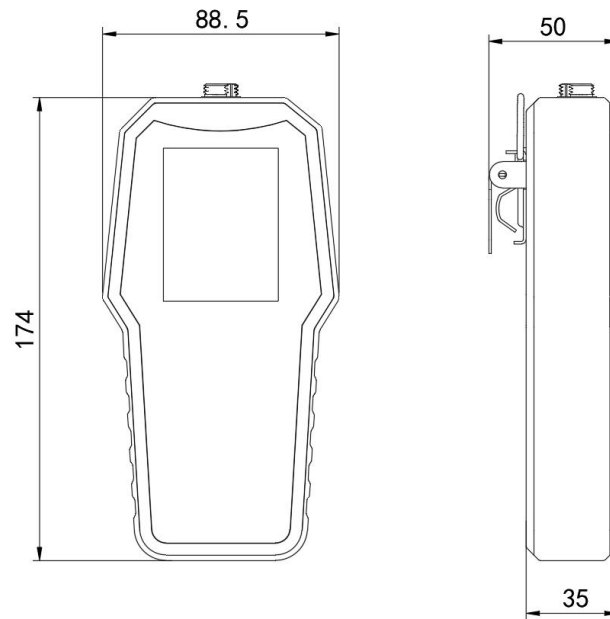

Equipment dimension drawing (unit: mm)

3. Instructions

3.1 Equipment List

- 1 recorder equipment
- 1 data line
- Certificate, Warranty Card

3.2 Structure description



3.3 Sensor connection device







First take out the aviation plug wire, plug the aviation plug adapter wire with the one-to-two-wire or one-to-three-wire, and then plug the one-to-two-wire or one-to-three-wire branch wire to the soil equipment, supporting up to four 485 sensors to be connected at the same time, and finally connect the The male end of the good aviation plug wire is connected to the aviation plug of Dr. Rang's recorder.



4. Function and operation instructions

4.1 Key Description

picture	name	explain
	up arrow key	Main interface: long press to turn on the sound when the alarm state is on, and long press to cancel the alarm sound when an

		alarm occurs; short press up on the menu interface to select setting items and increase the value; short press on the password interface to increase the value
	down arrow	Main interface: long press to turn off the sound when the alarm state is on Short press down on the menu interface to select the setting item and increase the value Short press on the password interface to decrease the value
	left arrow key	Short press left on the main interface to switch the display interface of different devices Short press on the menu interface to move the cursor to the left
	direction right	Short press right on the main interface to switch the display interface of different devices Short press on the menu interface to move the cursor to the right
	Enter	Host interface: long press to turn on or off data logging, short press to enter the password interface; Short press on the menu interface to confirm the selection
	return key	Short press on the menu interface to return to the previous interface; Any interface: long press to return to the main interface.
	Bluetooth printing (not yet developed)	Long press for one-key Bluetooth printing

	<p>Power button</p>	<p>Power off state: long press for 2S, the device enters the power on state; Main interface status: long press for 4S, the device is turned off,</p>
---	---------------------	--

4.2 Main interface introduction

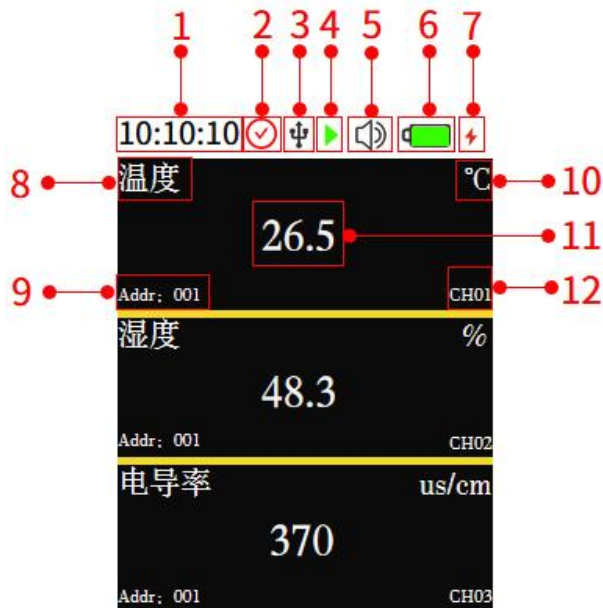

serial number	name	illustrate
1	time	Display the current time (manual adjustment)
2	Call the police	As shown in the figure, it means that the general alarm sound is turned on (the buzzer alarm can be turned off separately), when it is displayed, it means that the general alarm is turned on
3	USB socket	After plugging in the USB, this sign is displayed
4	data record	As shown in the figure, it means to open the record data (can be set to open or close the record data), when it is displayed, it means to close the record data
5	buzzer	As shown in the figure, the buzzer is normally enabled, and when the buzzer is disabled, it displays:  The buzzer cannot be enabled when the alarm is off
6	Electricity	Displays the current remaining battery level
7	charging sign	Show this logo when the device is charging
8	feature name	Measurement feature name

9	address	The 485 address of the device corresponding to the measurement element
10	unit	unit of measure
11	real-time value	Displays the current detection actual feature value
12	aisle	channel number

4.3 Instructions

1. In the off state, long press the confirmation button for 2S, the device detects whether the buzzer is in normal use, and the device enters the main interface
2. On the main page, short press the confirm key to enter the password interface, the default password is 0000, press the cycle key to move the cursor to confirm, and click the confirm key to enter the menu interface. As shown in Figure 1:



figure 1

4.3.1 System Equipment Description

Move the cursor to the corresponding icon and click the OK button to enter the setting interface

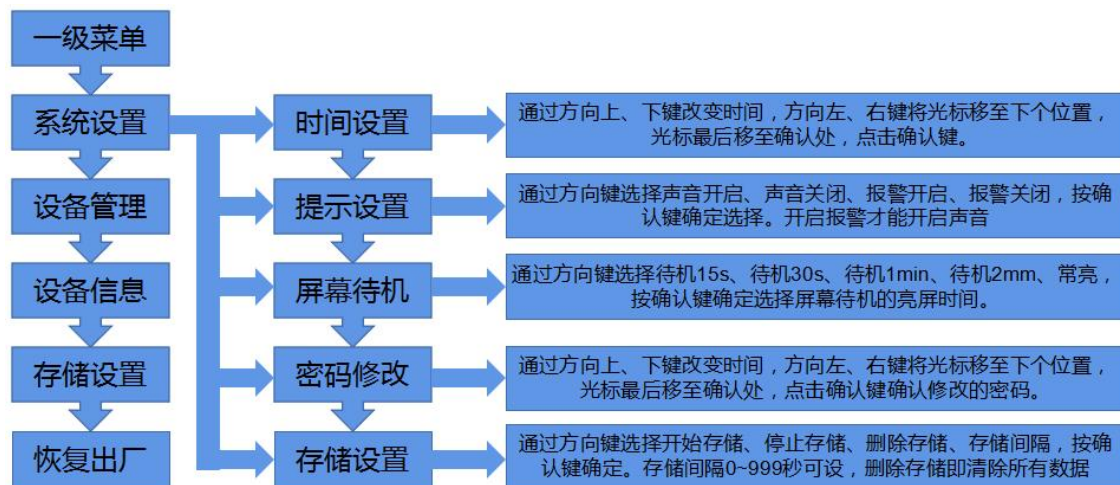

4.3.2 Device Management Instructions

Note: When connecting multiple sensors at the same time, the sensor addresses should

not conflict, so as to avoid confusion when the configuration software is viewing the data curve.

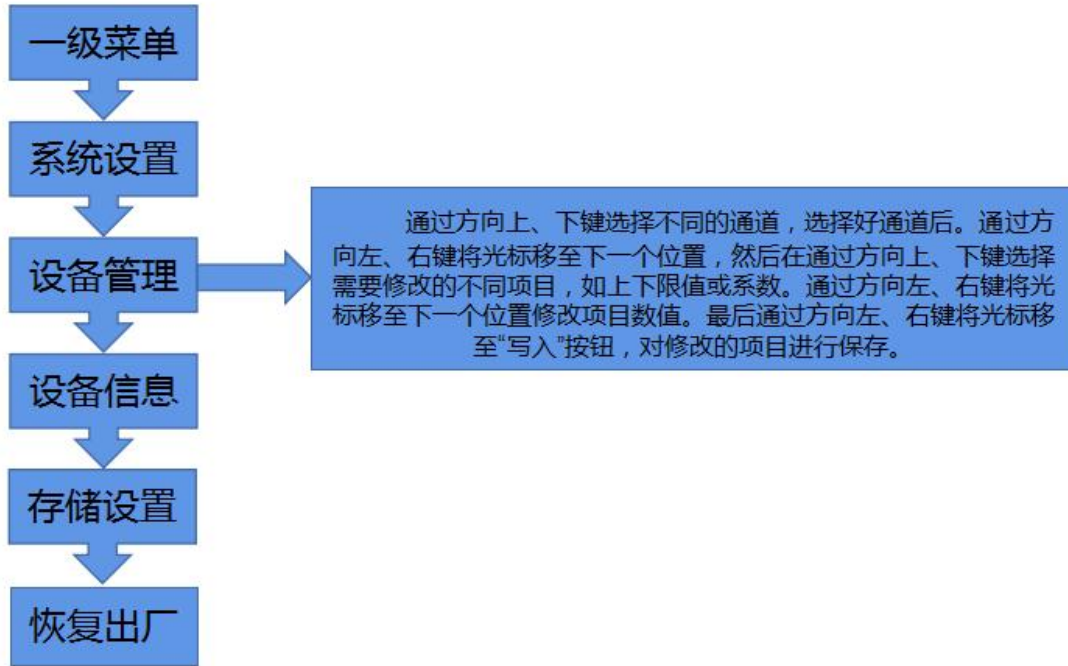

4.3.3 View historical data description

In this operation, you can view historical data on the device, and you can also import the device storage data into the computer for viewing. For specific operations, please refer to the instructions in Sections 5.4 and 5.5.

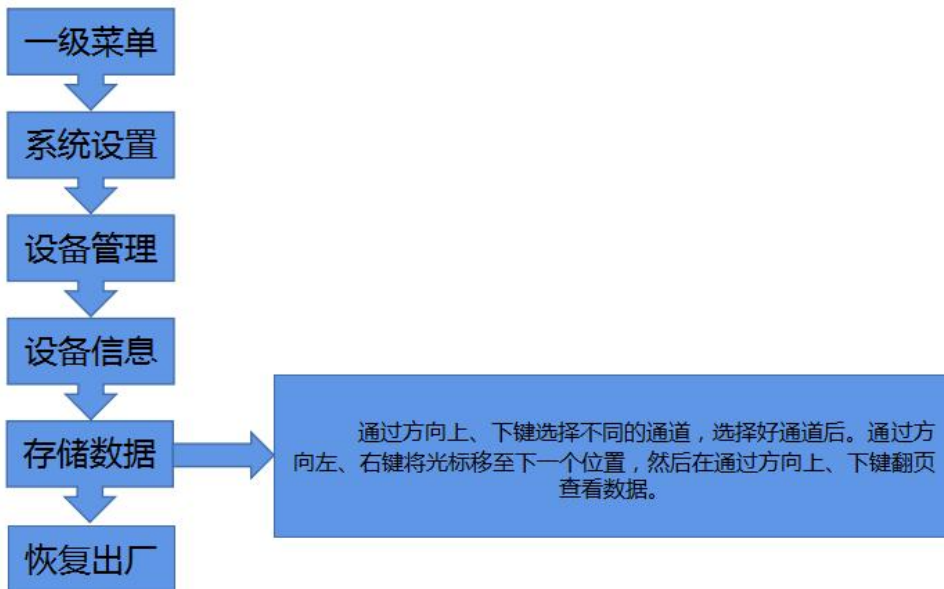

5. Configuration software instructions

After the software installation is complete, it will be generated on the



desktop "手持式记录仪" icon, double-click to open the software.

5.1 Device Information

Connect the device to the computer through the USB data cable, open the software and the device information will be automatically read. After editing the device parameters, click "Write Device Information" to write the parameters into the device.

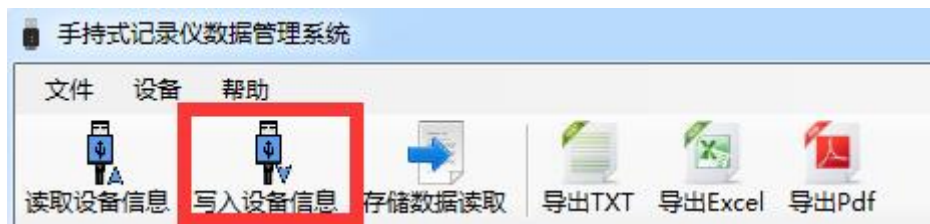

It should be noted that after the modified parameters, tick the modified parameters, and then click to write the device information, the parameter will be written to the device. This function is for the convenience of modifying other parameters by mistake when modifying individual parameters. set.

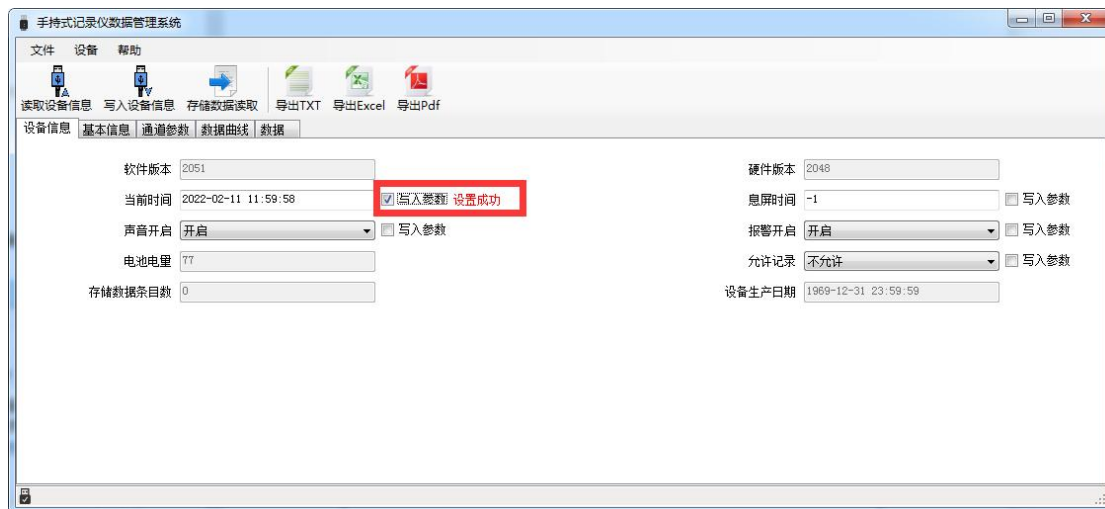

Software version: factory default, can be viewed but not modified.

Hardware version: Factory default, viewable but not modifiable.

Current time: You can check the clock time indicated by the recorder to determine whether you need to adjust the time.

Screen off time: 15 seconds, 30 seconds, 1 minute, 2 minutes, always on can be set, the default is 30 seconds.

Sound On: Set the alarm sound function of the recorder on or off.

Alarm On: Set the recorder's overrun alarm function on or off.

Battery power: the current remaining power of the detector.

Allow Recording: Set the storage function of the detector on or off.

Stored entries: the number of records currently stored by the detector (the total number of records of all sensors).

Equipment production date: factory default, can be viewed but not modified.

Recording Interval: Set the recording interval of the detector (default 60 seconds).

Current recording status: The data recording is turned on, and it is turned off by default.

5.2 Basic Information

Click "Read Parameters" to read the basic information of the device. If you need to modify the parameters, after modifying the parameters, click "Write Parameters" to send the parameters to the device.

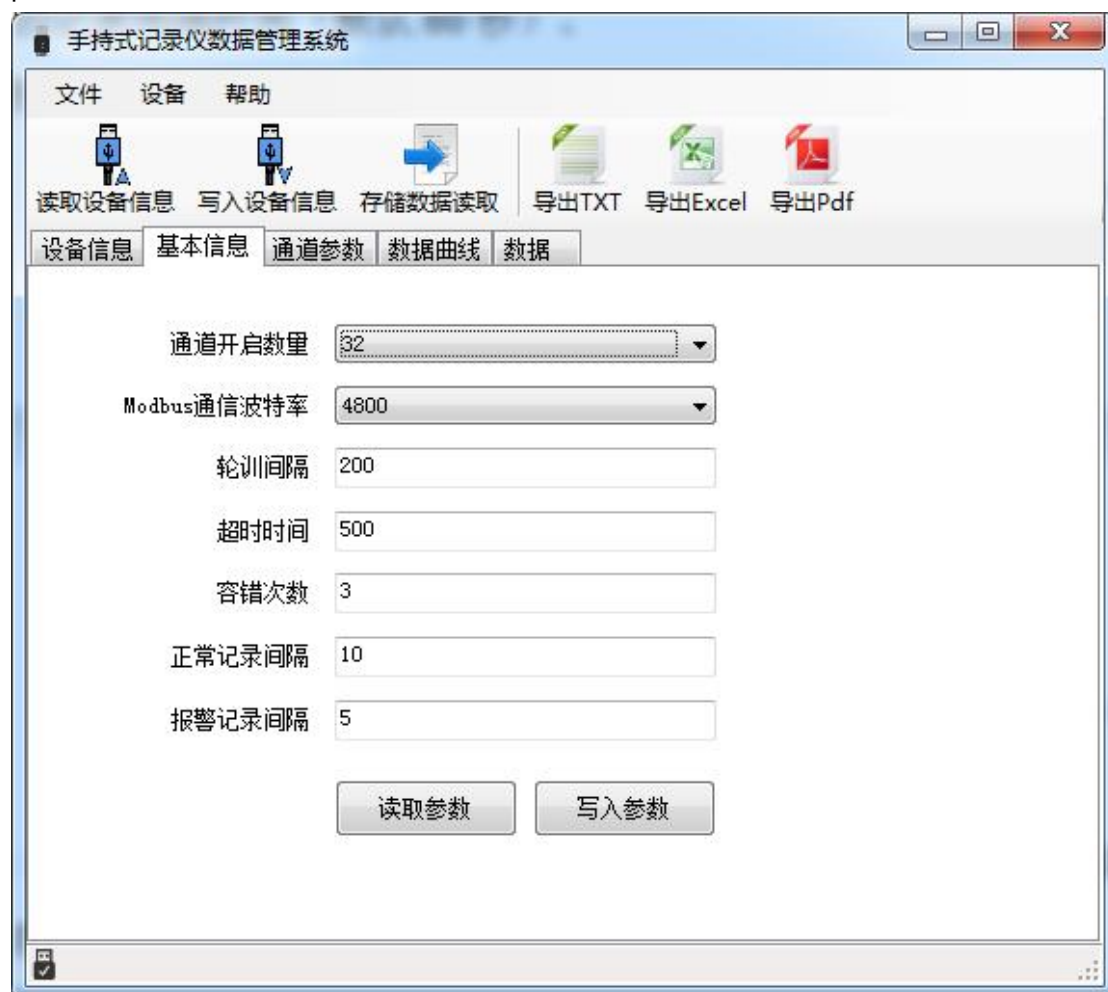

Number of channels open: Up to 32 channels can be opened at the same time, and each channel can measure one element.

Modbus communication baud rate: 2400, 4800, 9600, the 485 device connected to the recorder **must use the same baud rate**.

Polling interval: The polling interval between the main station port of the recorder and

the 485 device, 100~65565ms, the default is 500ms.

Timeout time: When the 485 device does not respond, the waiting time of the main station port of the recorder is 100~65565ms, and the default is 500ms.

Fault tolerance times: When the 485 device has no response, the number of inquiries from the main station port of the recorder, 1~65535, default 3.

Normal recording interval: the data recording interval when the device has no alarm, 1~999s, the default is 60s.

Alarm recording interval: The data recording interval when the device alarms, 1~999s, the default is 30s.

5.3Channel parameters

Select the channel you want to configure, click "Read Parameters" to modify the parameters of the channel, and after modifying the parameters, click "Write Parameters" to send the parameters to the device.

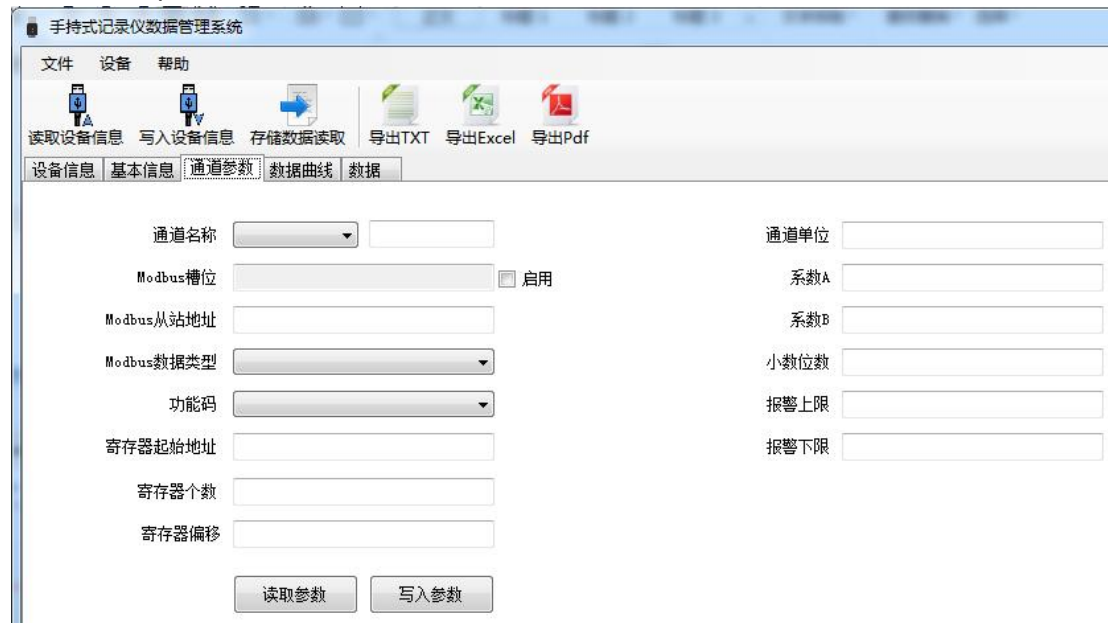

Channel Name: User-defined channel name, up to six Chinese characters.

Modbus slot: reserved.

Modbus slave address: The device address polled by the master.

Modbus data type: The data type of the 485 device register can be selected according to the actual situation. Big endian means that the high bits are in the front and the low bits are behind, and the little endian is the opposite.

Function code: 03/04, the default function code is 03.

Register start address: Set the start address of the register read by the channel.

Number of registers: Set the length of the registers to be read.

Register offset: When the device only allows to read fixed commands, the starting

register read will be read from the register after the offset value.

Channel Unit: The unit of the channel measurement element, which can be customized, up to six characters.

Coefficient A, Coefficient B: Value= $Ax+B$, the original value is processed by coefficient.

Decimal point: The decimal point position of the data display.

Alarm upper limit: set the upper limit, when the real-time value exceeds the upper limit, the device will alarm.

Alarm upper limit: set the lower limit, when the real-time value is lower than the lower limit, the device will alarm.

5.4 Import Data

Connect the recorder to the computer via a USB cable, and then open the handheld recorder configuration software. The software will automatically read "read device information", and then click "stored data read" to import the data stored in the detector into the configuration software.



Click on the data to view the stored historical data in time.

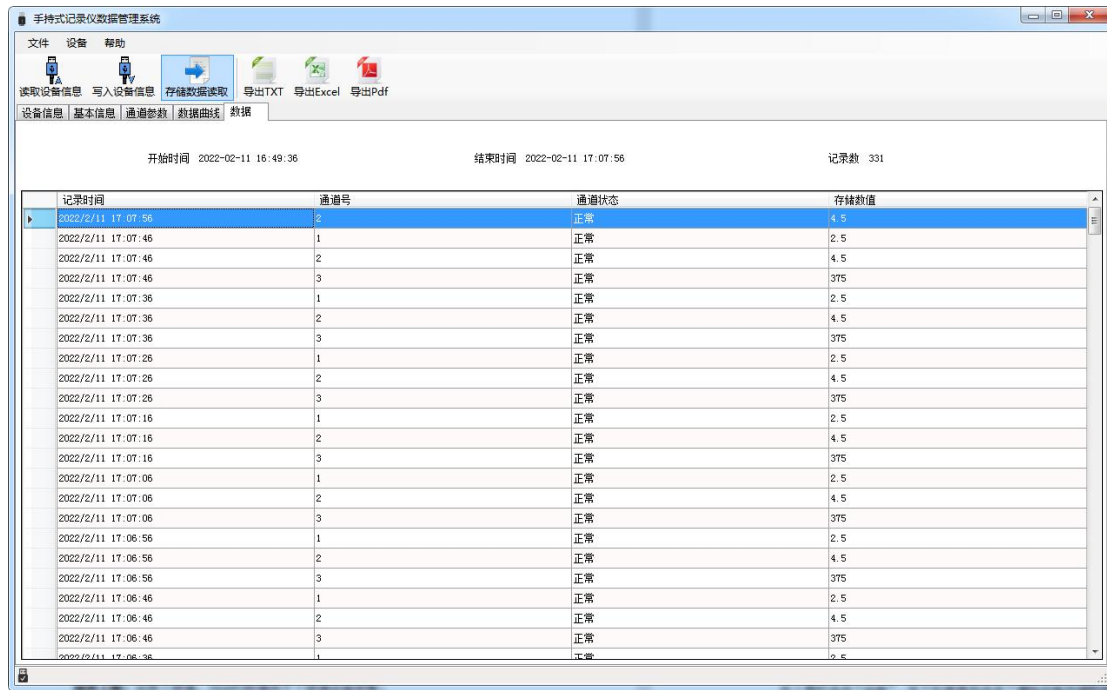

5.5 export data

Select the export format (TXT/XLS/PDF) on the toolbar to save the data to the specified path (take PDF as an example), indicating that the export is successful.

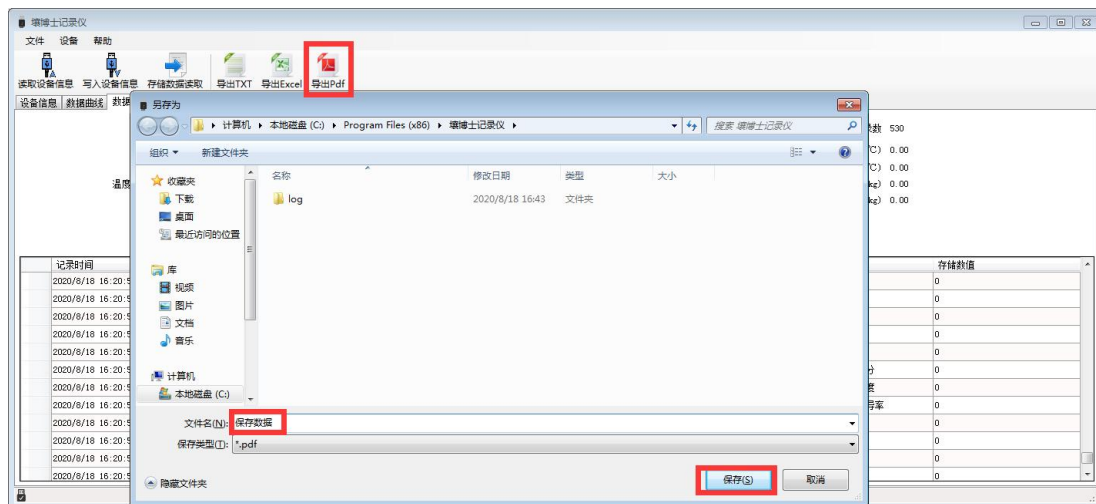

5.6 Clear device data

Click "Device" on the toolbar, and click "Clear Device Storage Data" in the drop-down menu to clear the device data. After clearing, the software prompts "Data Cleared Successfully".

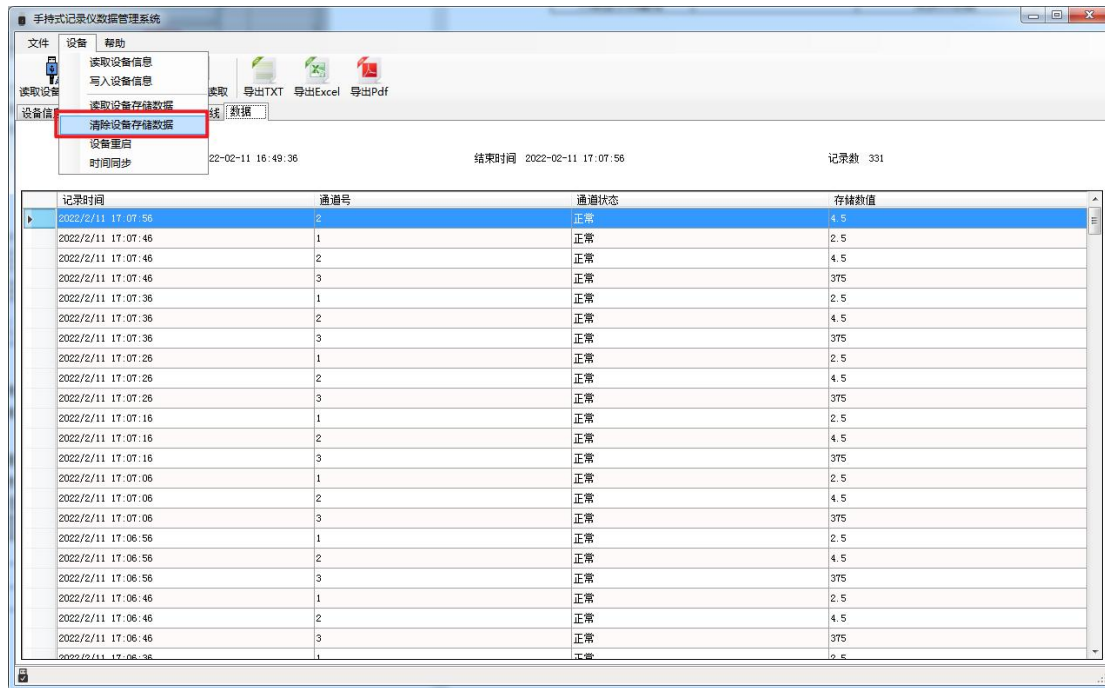

6. Description of charging function

When the device is turned off, connect the charger to the recorder, and connect the other end to the AC220V AC power supply. After the detector is fully charged, the battery will display full, and it can be used normally.

7. Precautions

1. Prevent the machine from falling from a height or being subjected to severe vibration.
2. Please use the recorder strictly in accordance with the instructions, otherwise it may cause inaccurate test results or damage the product.

8. Common faults and solutions

fault phenomenon	Possible cause of failure	How to handle
Can not boot	Voltage is too low	Please charge in time
	crash	Please contact dealer or manufacturer for repair
	circuit failure	Please contact dealer or manufacturer for repair
Inserting the sensor does not respond	circuit failure	Please contact dealer or manufacturer for repair
Display is not accurate	sensor failure	Please contact the dealer or manufacturer Replace the sensor
	long-term uncalibrated	Please mark in time

time display error	The battery is completely drained	Replace the RTC battery and reset the time
	Strong electromagnetic interference	reset time
When the instrument detects normally The interface shows the full scale	sensor failure	Please contact the dealer or manufacturer Replace the sensor