

# YW04-S

## 76-81GHz continuous frequency modulated wave radar level meter Instruction Manual



SIBO.X INDUSTRIAL CO.,LTD.

Add: No. Building 1, No. 1, Jingshi Road, Cicheng Town Industrial Park, Jiangbei District, Ningbo City, Zhejiang, China

<https://www.sbxsun.com>

Email: [info@sbxsun.com](mailto:info@sbxsun.com)

Tel: +86-15958288207

## Table of Contents

1.Product description .....	1
2.Technical Support .....	1
3.Dimensions .....	2
4.Install .....	4
5.Product wiring .....	6
6.Key Description .....	7
7.Edit menu description .....	8

## 1.Product description

76-81GHz frequency modulated continuous wave (FMCW) radar products support four-wire and two-wire applications. Multiple models, the maximum range of the product can reach 120m, and the blind zone can reach 10 cm. Because it operates at a higher frequency and shorter wavelength, it is especially suitable for solid-state applications. The way it emits and receives electromagnetic waves through a lens has unique advantages in high-dust, harsh temperature environments (+200°C). The instrument provides flange or thread fixation methods, making installation convenient and easy.

### The main advantages of this series are as follows:

- ▷ Based on self-developed CMOS millimeter-wave radio frequency chips, it achieves a more compact radio frequency architecture, higher signal-to-noise ratio, and smaller blind areas.
- ▷ The 5GHz operating bandwidth enables the product to have higher measurement resolution and accuracy.
- ▷ The narrowest antenna beam angle is 3°, interference in the installation environment has less impact on the instrument, and installation is more convenient.
- ▷ The wavelength is shorter and has better reflection characteristics on solid surfaces, so there is no need to use a special gimbal flange for aiming.
- ▷ Supports Bluetooth debugging on mobile phones to facilitate maintenance work by on-site personnel

## 2.Technical Support

Transmission frequency	76GHz~81GHz,
Measuring range	15m 35m 85m 120m
Measurement accuracy	±1mm
Beam angle	3°、6°
Power supply range	18~28.0VDC
Communication method	HART/MODBUS
Signal output	4~20mA & RS-485
Shell material	Aluminum casting, stainless steel
Antenna type	Threaded model/universal model/flat model/flat heat dissipation model/high temperature and high pressure model
Cable entry	M20*1.5
Recommended cables	0.5mm <sup>2</sup>
Protection level	IP68

### 3.Dimensions

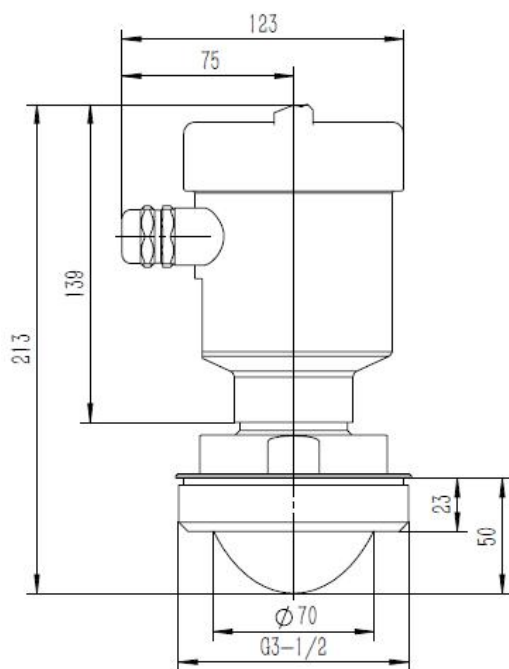

Schematic diagram of normal temperature structural dimensions of pipe thread process connection

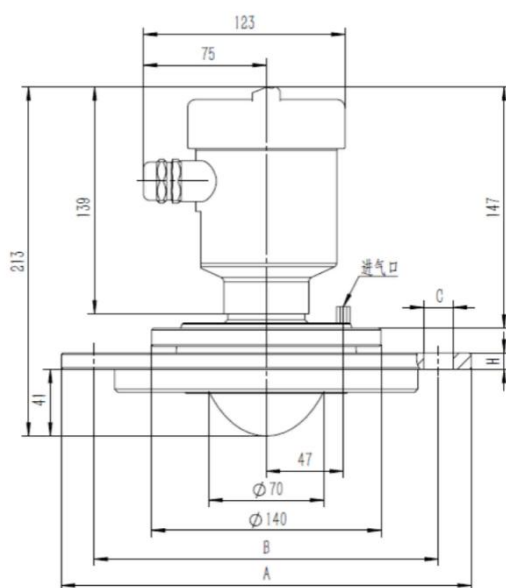

	A	B	C	H
DN80	$\phi 200$	$\phi 160$	8- $\phi 16$	15
DN100	$\phi 220$	$\phi 180$	8- $\phi 16$	15
DN125	$\phi 250$	$\phi 210$	8- $\phi 16$	17
DN150	$\phi 285$	$\phi 240$	8- $\phi 20$	17
DN200	$\phi 315$	$\phi 270$	8- $\phi 20$	19

Dimensional diagram of universal flange universal high temperature structure

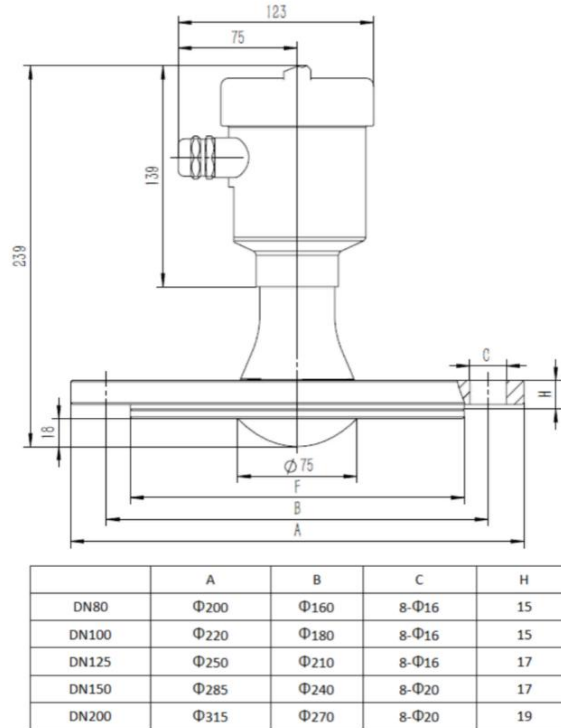

Structural dimension diagram of anti-corrosion model

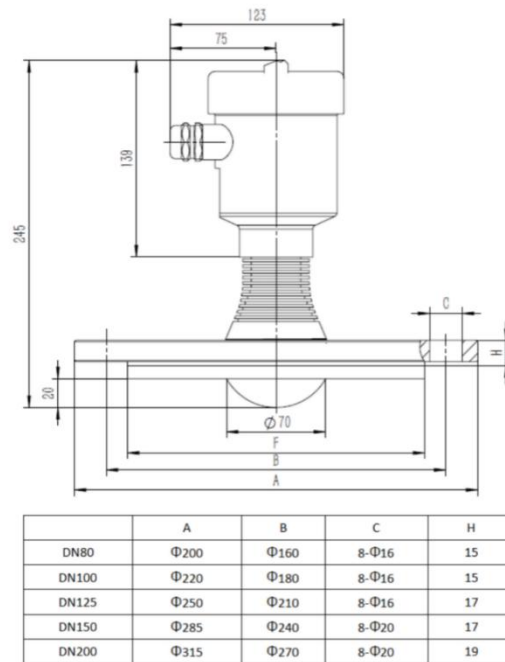

Schematic diagram of anti-corrosion high temperature structure dimensions

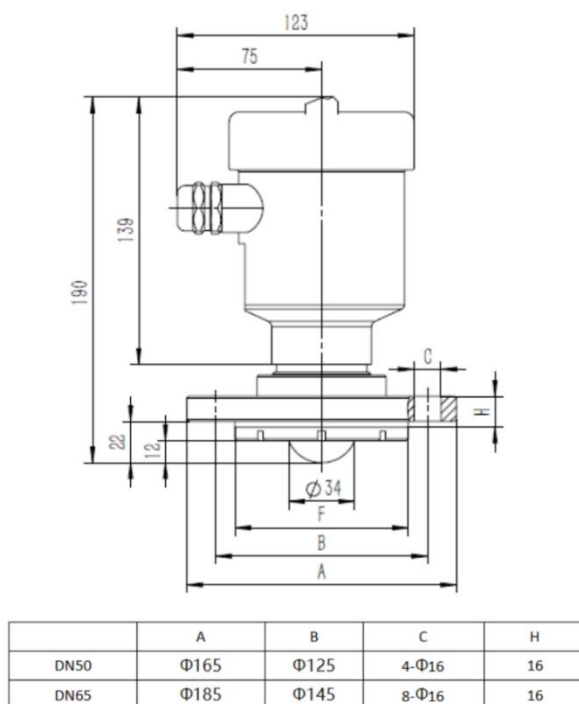

Structural dimension diagram of anti-corrosion model

## 4.Install

Two points need to be paid attention to during installation:

- ▷ Aim at the target material level and try to ensure vertical incident material level; avoid false echoes. See the following points for typical working conditions.
- ▷ Make sure there are no interference objects within the beam range, such as ladders and steps.

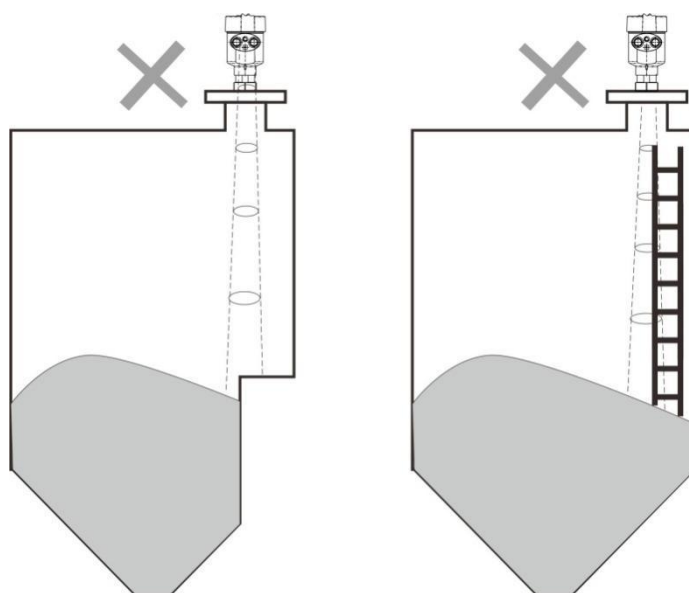

Instrument installation location diagram

The instrument should be installed at least 20cm away from the container wall, otherwise erroneous readings may occur.

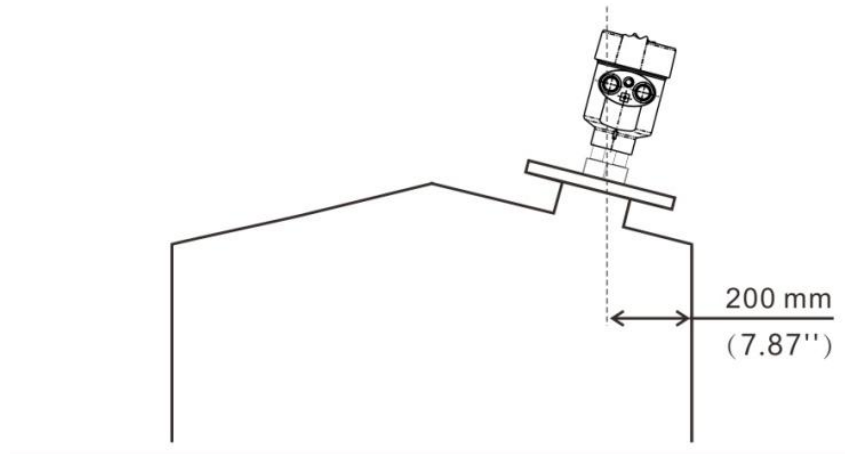

Install at least 20cm away from the container wall

The instrument installation should ensure that the antenna beam avoids the feed opening, as shown in the figure.

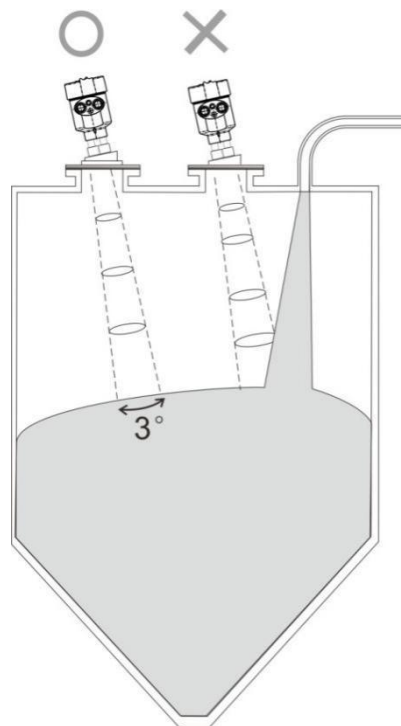

Antenna beam avoids feed opening

For conical containers, try to ensure that the beam hits the bottom of the tank directly, otherwise the measurement results at the bottom of the tank may be inaccurate.

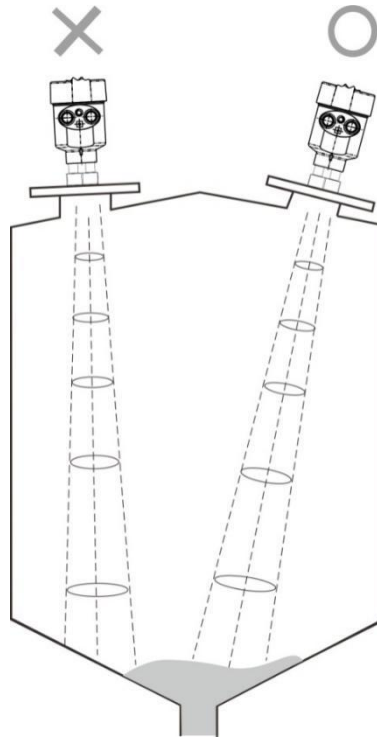

The tapered tank should try to ensure that the beam reaches the bottom of the tank directly.

## 5.Product wiring

▷ Single cavity housing 24VDC power supply two-wire product wiring diagram

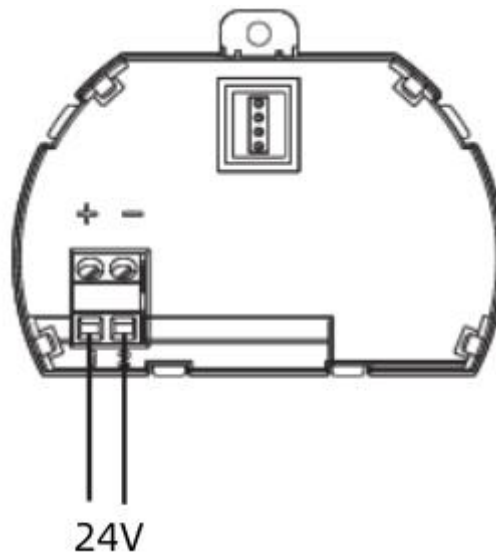

Schematic diagram of two-wire products

▷ Single cavity housing 24VDC power supply four-wire product wiring diagram

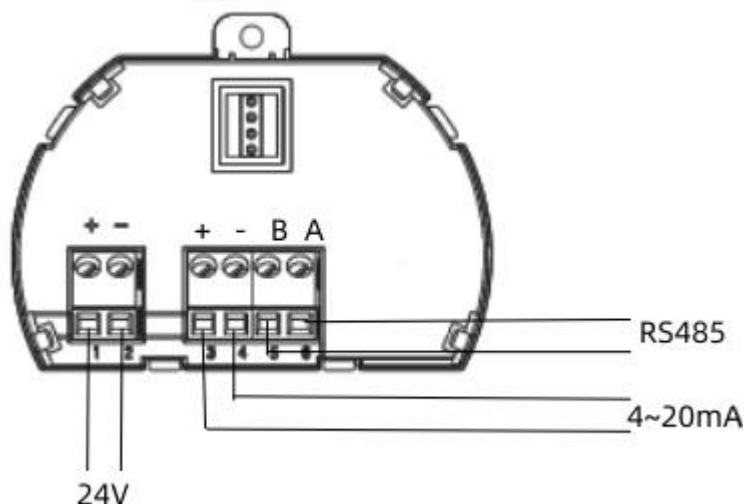

Schematic diagram of four-wire products

In four-wire applications, in addition to the 24v power supply terminal, the 4-20ma analog output is two separate terminals. At the same time, the four-wire system also provides 485 output terminals.

## 6.Key Description

There are 4 buttons on the instrument panel, through which the instrument can be debugged. The debug menu is language selectable. After debugging, the LCD screen displays the measured value, and the measured value can be read very clearly through the glass window. (panel diagram)

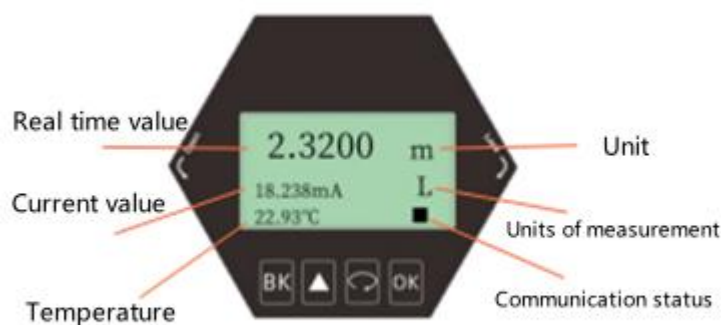

### [OK] key

- Enter programming state;
- Confirm programming items;
- Confirm parameter modification.

### [↶] key

- Select programming items;
- Choose to edit parameter bits;

-Parameter item content display;

[△] key

- Modify parameter values;
- Select display mode

[BK] key

- Exit programming state;
- Return to the previous menu;
- Measurement value/echo waveform switching during operation.

## 7.Edit menu description

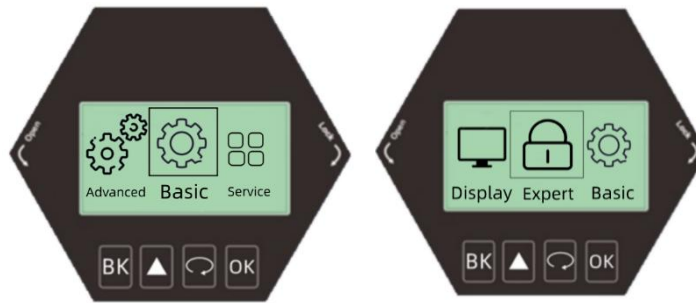

### 7.1. Basic settings

#### 7.1.1 High and low adjustment

【Low adjustment】 is related to the range setting. Together with 【High Adjustment】 , it maps the corresponding relationship between the measured value and the current output (4-20mA).

Select 【Low Adjustment】 in the 【Basic Settings】 menu, press the 【OK】 button to enter 【Low Adjustment】 , the display is as follows:



### 7.1.2 Range setting

In order to obtain correct measurement results, the measuring range of the instrument needs to be set. Select the **【Basic Settings】** menu, enter the **【Range Settings】** option, press the **【OK】**



button, and enter **【Low Adjustment】**, as shown below:

### 7.1.3 Blind zone setting

When there are fixed obstacles that interfere with the measurement close to the sensor surface, and the maximum material height will not reach the obstacle, you can use the blind zone range setting function to avoid measurement errors. Enter the **【Basic Settings】** menu and select **【Blind Zone Settings】**, press the **[OK]** button to enter the option editing blind area.



### 7.1.4 Damping time

In order to improve the stability of the measurement output value, you can set a larger **【damping time】** to achieve stable measurement values and increase the anti-interference ability. For example, if the damping time is 2 seconds, the position of the measured object undergoes a step change at time  $t$ , and the measurement output value follows the actual position of the measured object 10 seconds later, enter the **【Basic Settings】** menu, select **【Damping Time】**, and press **[OK]**, the display is as shown below:



Parameter name	Damping time
Parameter range (S)	0~100
Default value(S)	5
Associated configuration	None
Option meaning	Damping output to improve signal stability
Special matters	None

### 7.1.5 Media type

Enter the **【Basic Settings】** menu, select **【Media Type】** , and press the [OK] button to enter the container type selection menu.

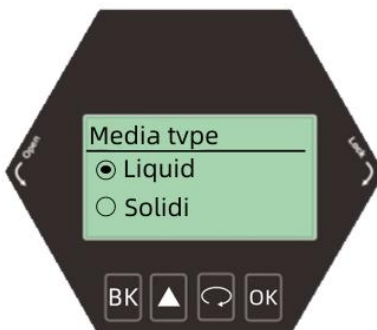

### 7.1.6 Container types

Enter the **【Basic Settings】** menu, select **【Container Type】** , and press the [OK] button to enter the container type selection menu.

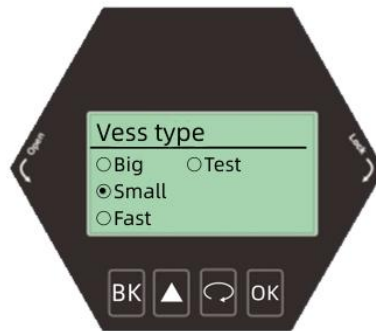

Big	This parameter pursues stable measurement output.
Small	Adapt to most working conditions
Fast	Suitable for working conditions requiring rapid measurement
Test	0 delay suitable for infield testing

## 7.2. Advanced settings

### 7.2.1 False echo learning

【False echo learning】 can learn false echoes in containers containing known obstacles and form a screening curve (threshold curve) for background noise. Before learning false echoes, you need to set 【false echo mode】 and 【False echo area】 . Enter the 【Advanced Settings】 menu and select 【False Echo Learning】 , as shown in the figure below.

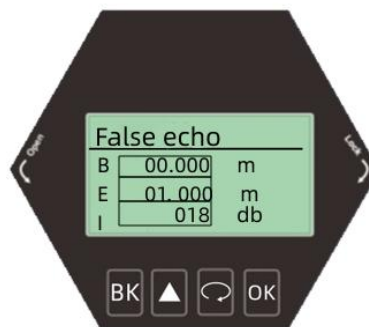

Envelope amplitude and echo value plots

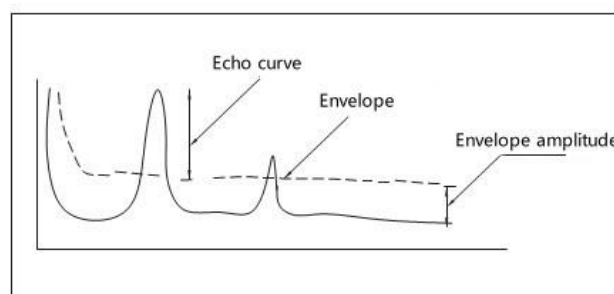

### 7.2.2 Distance offset

Set **【Distance Offset】** to correct the deviation between the ideal measurement value and the actual measurement value. Enter **【Advanced Settings】** and select **【Distance Offset】**, as shown below:

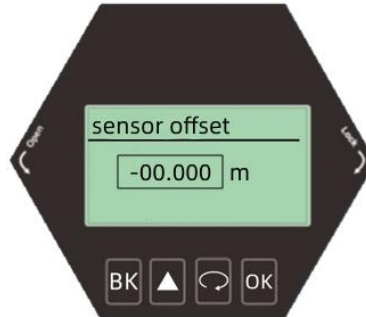

### 7.2.3 Bus address

Set different **【bus addresses】** and integrate them into the network at the working site. Enter **【Advanced Settings】** and select **【Bus Address】**, as shown below:



### 7.2.4 Output location

Set **【20mA position】**, the meter defaults to output 20mA when the measured value is the **【High Adjustment】** value. The user can customize the 20mA position of 4-20mA output according to actual needs, enter **【Advanced Settings】**, select **【20mA Position】**, Displayed as follows:

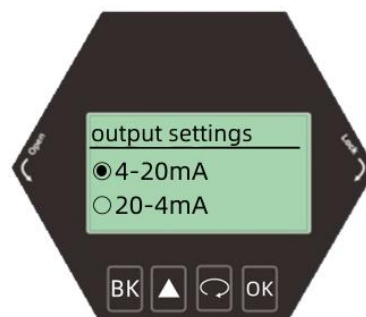

### 7.2.5 Current simulation

To calibrate the error value of the current output, it has been calibrated before leaving the factory. Enter **【Advanced Settings】** , select **【20mA Position】** , and the display is as follows:

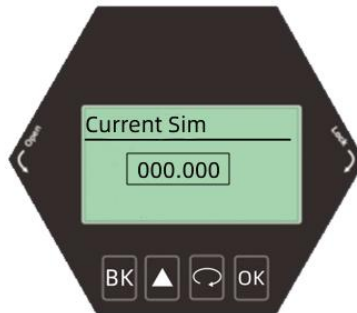

### 7.2.6 Current function

You can set the actual output current value when the instrument encounters a wave loss fault. Enter **【Advanced Settings】** and select **【Current Function】** , as shown below:

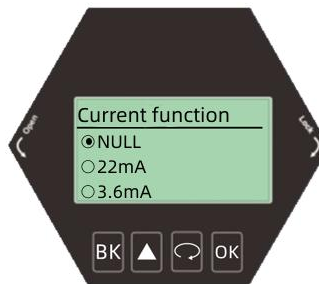

## 7.3. Service

### 7.3.1 Echo rate

**【Echo Rate】** is used to adjust the speed of the waveform change. The larger the value, the slower and more stable the waveform changes. On the contrary, the smaller the value, the faster the waveform changes. Enter **【Service】** , select **【Echo Rate】** , and the display is as follows:



### 7.3.2 Window settings

Used to search the front and back range after locking the waveform. After the current echo is locked, it will search for the strongest echo back and forth within the set range. If the current echo is

lost, or the loading and unloading is too fast and the echo is not tracked, it will search for the strongest echo throughout the process. And confirm the current echo. If the previously lost echo is restored, the previously lost echo will not be confirmed. In terms of time, it is the speed of arrow tracking. Enter **【Service】** , select **【Window Settings】** , and the display is as follows:



### 7.3.3 Echo ratio

The percentage of the echo outside the window that is greater than the echo within the window, enter **【Service】** , select **【Echo Ratio】** , the display is as follows:



### 7.3.4 Echo locking

If you choose to lock, you will search for signals within this window range (the window range here refers to the parameters set in the previous window). To unlock, you need to search for signals throughout the process, enter **【Service】** , select **【Echo Lock】** , and the display will be as follows:



### 7.3.5 First-level filtering

**【First-level filtering】** In a small-range measurement environment, you can choose to turn it on or off according to the waveform. Enter **【Service】**, select **【First-level filtering】**, and the display is as follows:

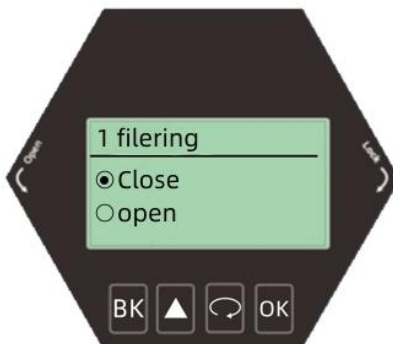

### 7.3.6 Secondary filtering

**【Secondary filtering】** is an interface filter that can be turned on or off according to the waveform in a large-range measurement environment. Do not use it if the blind zone is too small. Enter **【Service】** and select **【Second-level filtering】**. The display is as follows:

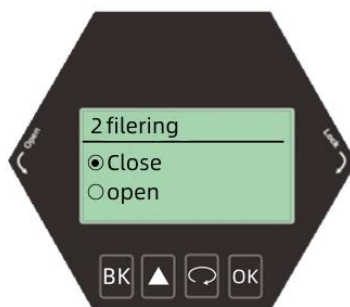

### 7.3.7 Response rate

It is used to adjust the response rate of the instrument to the actual material level increase. When the rate and time settings are changed, the response rate will automatically change. Generally, the solid rate setting is slightly larger and the liquid rate is slightly smaller. Enter **【Service】**, select **【Response Rate】**, and the display is as follows:

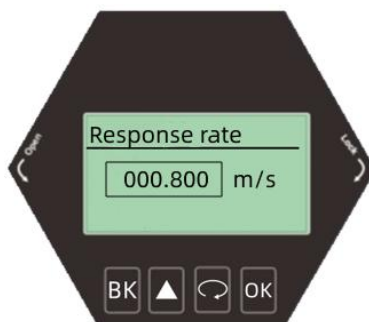

### 7.3.8 Threshold setting

Set the threshold size of the effective echo. The larger the threshold setting, the stronger the effective echo amplitude on site is required, which is conducive to eliminating the interference of small signal clutter. Enter **【Service】** , select **【Threshold Setting】** , and the display is as follows:



## 7.4. Display

### 7.4.1 Measurement mode

It can display three modes: material level, empty height and ratio. Enter **【Display】** and select **【Display Mode】** . The display is as follows:

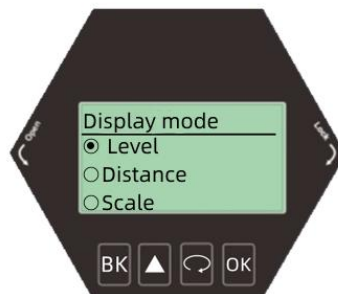

### 7.4.2 Distance unit

Change the unit according to your needs. The unit is divided into three types: "m" "cm" "mm". Enter **【Display】** and select **【Distance Unit】** . The display is as follows:

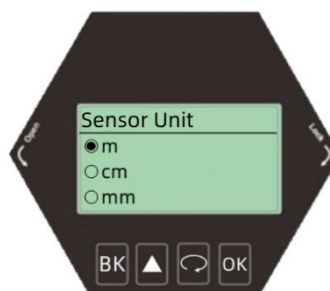

### 7.4.3 Language

You can choose Chinese, English, Korean, enter **【Display】** , select **【Language】** , the display is as follows:



#### 7.4.4 LCD contrast

You can adjust the brightness of the display screen, select **【LCD】** , enter **【Display】** , select **【LCD Contrast】** , the display is as follows:



#### Schedule 1

Beam angle: Beam width with a limit of 3dB lower than the maximum value.

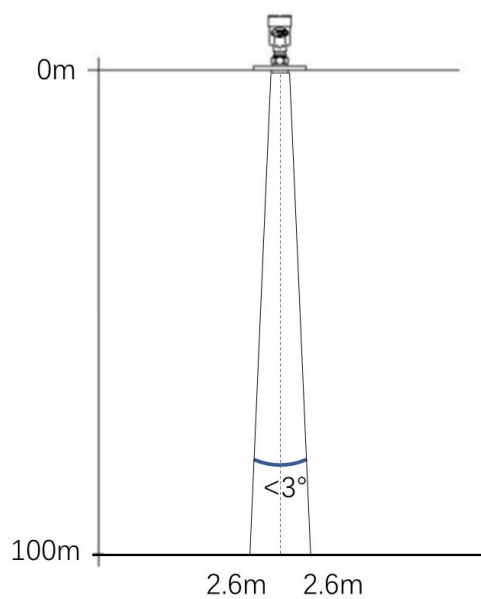

Schematic diagram of radar beam spatial geometry