

# YWBLE-B

## Bluetooth Capacitive Fuel Level Sensor

### User Manual



SIBO.X INDUSTRIAL CO.,LTD.

Add: No. Building 1, No. 1, Jingshi Road, Cicheng Town Industrial Park, Jiangbei District, Ningbo City, Zhejiang, China

<https://www.sbxsun.com>

Email: [info@sbxsun.com](mailto:info@sbxsun.com)

Tel: +86-15958288207

## Contents

1. Product Overview.....	1
1.1 Product Introduction.....	1
1.2 Product Features.....	1
1.3 Product Parameters.....	1
2. Product Installation.....	2
2.1 Installation Tools.....	2
2.2 Sensor cutoff.....	2
2.3 Sensor Calibration.....	4
2.3.1 APP Installation.....	4
2.3.2 Sensor Connection.....	5
2.3.3 Password Settings.....	6
2.3.4 Parameter settings.....	7
2.3.5 Calibration.....	8
2.4 Sensor Installation.....	10
2.5 Acceptance.....	12
3. Common fault description.....	13
4. Precautions.....	13
5. After-sales service.....	14

## 1. Product Overview

### 1.1 Product Introduction

YWBLE-B fuel level sensor adopts capacitive detection technology and is widely used in the measurement of liquid levels such as diesel, gasoline, lubricating oil, palm oil, etc. The core component of the product adopts a highly integrated dedicated capacitance measurement chip. After precise temperature compensation and linear correction, it has the advantages of high accuracy, high stability, and continuous measurement. Built-in Bluetooth module, compatible with a variety of Bluetooth GPS positioning terminal devices on the market. Built-in battery, no external power supply required, simple and convenient installation. Can be truncated arbitrarily according to the size of the fuel tank.

This product is suitable for remote fuel monitoring of freight trucks, construction machinery vehicles, buses, agricultural vehicles, special vehicles, and generator sets.

### 1.2 Product Features

- 1) Built-in Bluetooth communication module, wireless data transmission, no wiring required, quick installation.
- 2) Can be truncated arbitrarily according to the size of the fuel tank.
- 3) Parameters can be configured through mobile applications.
- 4) Built-in high-capacity battery, can be used continuously for 3 years.

### 1.3 Product Parameters

Technical content	Technical Parameters
Product Model	YWBLE-B
Measuring Range	10mm~1000mm
Signal Output	Bluetooth communication (BLE5.0)
Measuring Medium	Gasoline/diesel/lubricating oil/cooling oil
Operating Voltage	3.6V

Measurement Accuracy	$\leq \pm 1\%FS$
Operating Temperature	$-40^{\circ}C \sim +80^{\circ}C$
Delay Time	1 second to 1800 seconds can be set
Battery Capacity	4000mA (3 years of use)
Overall Structure	Column type
Main Materials	Aluminum Alloy
Flange Size	Outer diameter 70mm - Inner diameter 20mm
Installation Type	Top Mount
Transmission Distance	50m (No interference and obstacles)
Receive/Transmit Sensitivity	-96/4dBm

## 2. Product Installation

### 2.1 Installation Tools



Tool List

Tool Name	Quantity
Fuel level sensor	1pcs
Nitrile sealing rubber ring	1pcs
Tape measure	1pcs
Hand saw	1pcs
Marker pen	1pcs
Needle Nose Pliers	1pcs
Drill and Drill Bits	1pcs ( $\phi 32 - \phi 35m$ )
Self-tapping Screws	6pcs (hexagon)
Smartphone	1pcs (Install the App)

### 2.2 Sensor cutoff

**Note:** This sensor is a cut-off type sensor and can be cut off arbitrarily according to the size of the fuel tank.

**Step 1:** Use a tape measure to measure the height of the fuel tank. Note that the length of the fuel sensor is 1 cm less than the outer diameter of the fuel tank. (To prevent errors in measuring the fuel tank size and causing the sensor to fail to install). See the following figure for the measurement method:

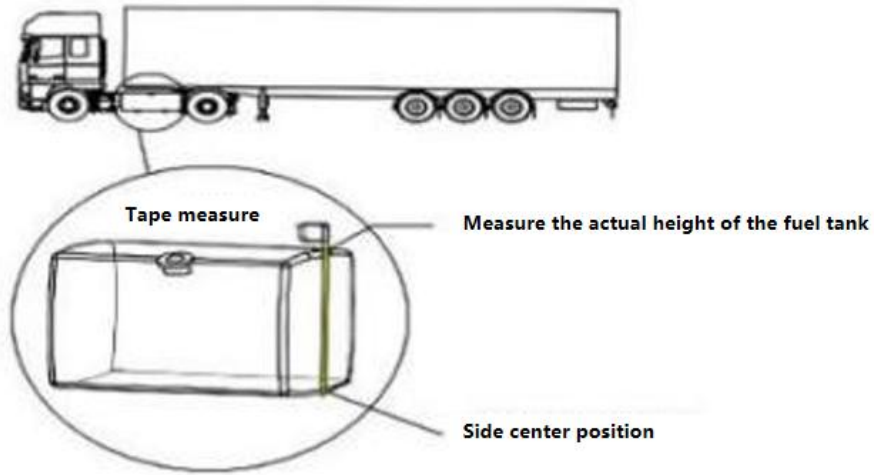

**Step 2:** Calculate the required length of the fuel level sensor based on the measurement results, mark the fuel level sensor with a marker, and cut along the mark with a hand saw. (Note: The length of the sensor after cutting cannot be shorter than 25CM)

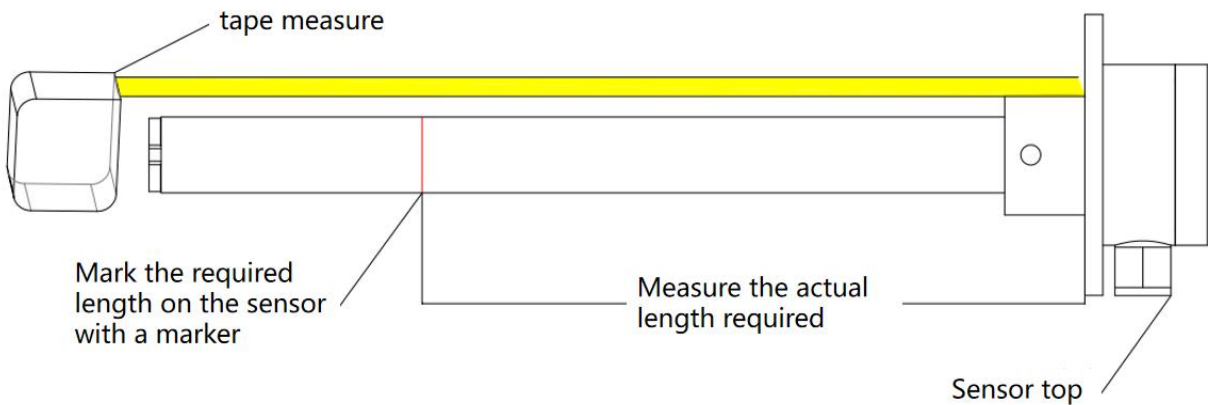

**Step 3:** After the sensor is cut to the required length, use a blade to scrape off the burrs generated during cutting. As shown in the figure below:

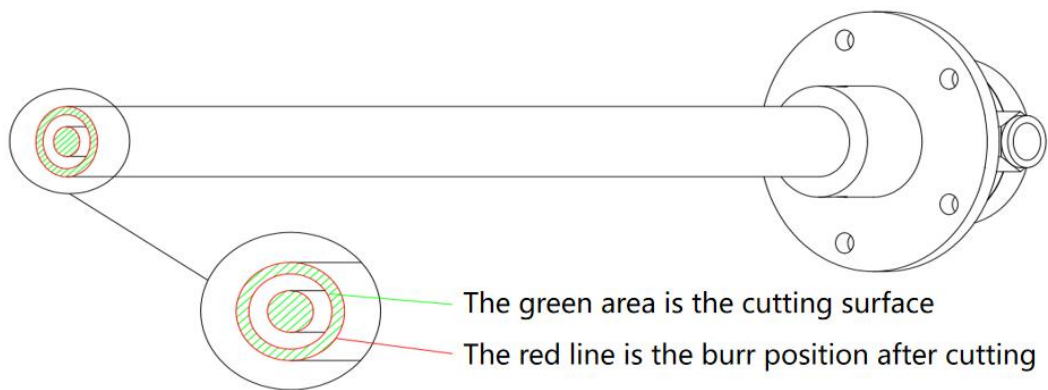

**Step 4:** After cutting, remove the original plug at the bottom of the sensor, reinstall it on the bottom of the sensor and tighten it so that it fits the bottom.

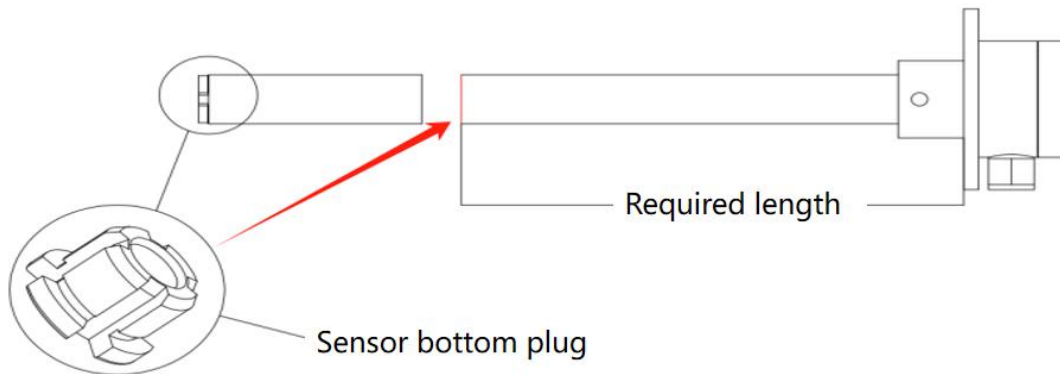

## 2.3 Sensor Calibration

**Note:** After the sensor is cut, it needs to be recalibrated to calibrate its new "full" and "empty" calibration values.

### 2.3.1 APP Installation

Get the APP in the following ways:

1. On Android, Use mobile browser or WeChat to scan the QR code below to download the App.



App download link: <https://wldata.5ljs.net.cn/ys2024/ys1008.apk>

2. On iOS, Search for "us Ble Sensor" in the App Store and download and install the APP, as shown in the following figure:

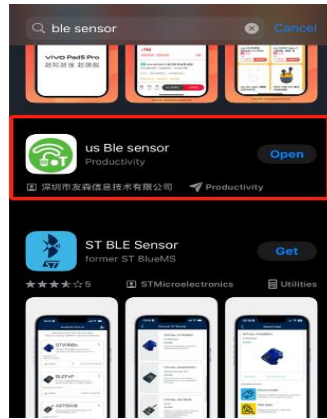

### 2.3.2 Sensor Connection

**Note:** The "BLE VERSION SENSOR" App needs to obtain the smartphone's geolocation access permission. Turn on Bluetooth and the smartphone's geolocation, or manually turn on the location information in the phone's "Settings" (as shown below).

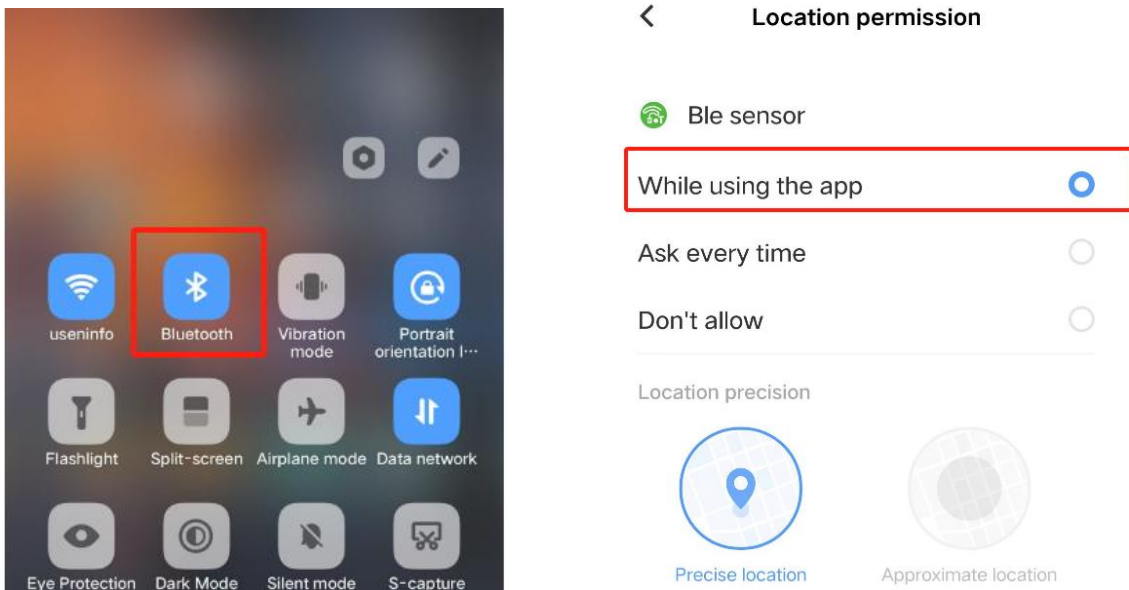

Go to the App homepage and click "Device List" → "Sensor Device" → Search for nearby Bluetooth devices for matching and connection.

After searching for nearby Bluetooth data that matches our serial port, we need to connect based on the MAC address marked on the fuel level sensor.

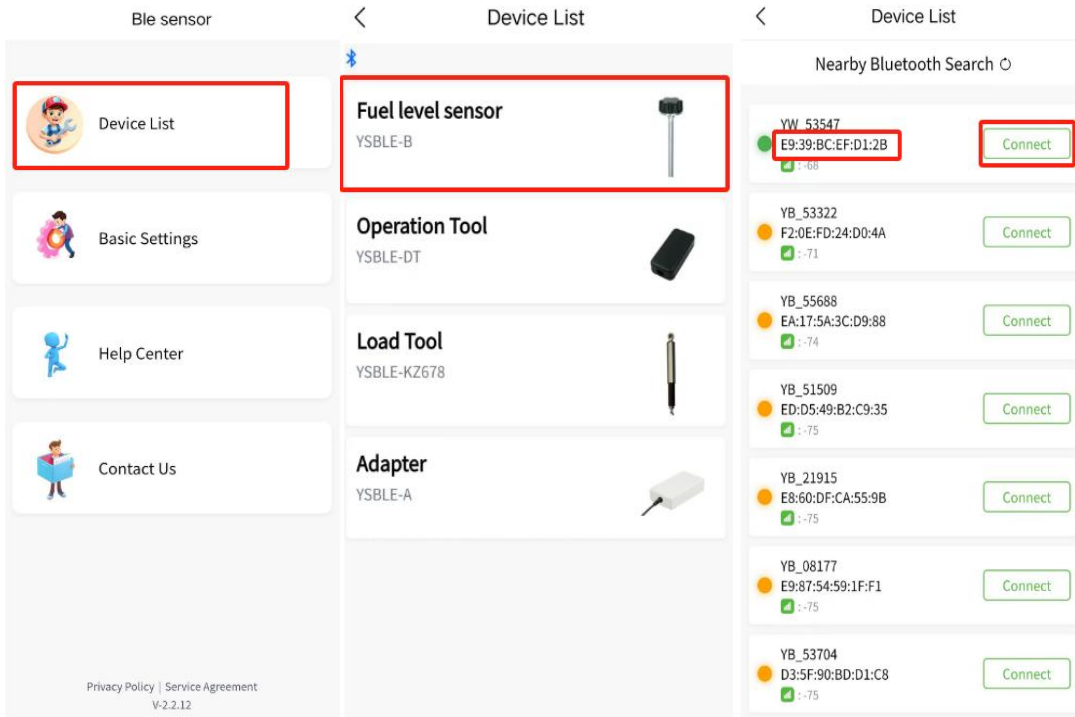

Connect according to sensor code

### 2.3.3 Password Settings

A password needs to be set to restrict access to configuration changes of the sensor. When connecting to the sensor for the first time, the application will automatically ask for a password. The password must be 6 digits. After the password has been set, you can enter the "Password" menu again to reset the password or delete the password (as shown in the picture):

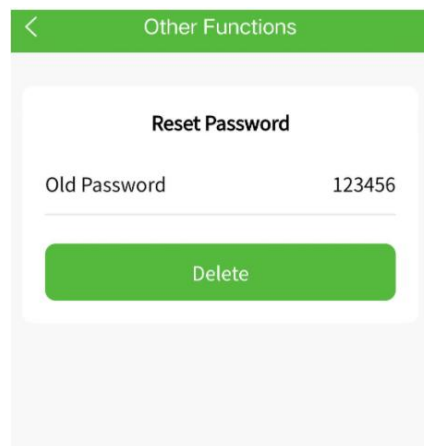

### 2.3.4 Parameter settings

In the sensor settings menu, you can manually set the maximum value and damping coefficient (filtering) of the fuel level sensor, as shown in the following figure:

(Setting the damping coefficient can improve the stability of the data. It is factory default and it is not recommended to change it.)

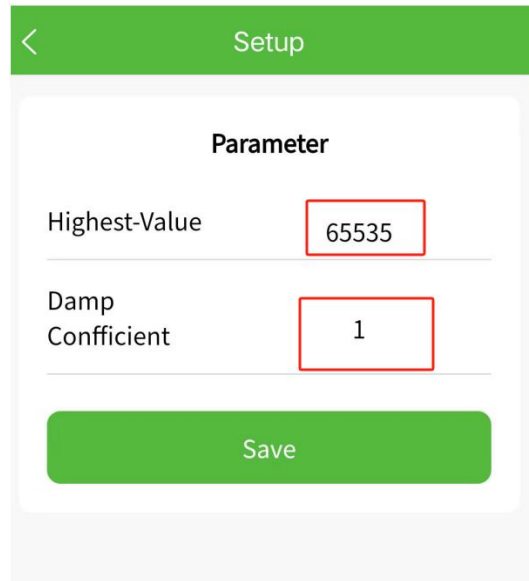

**Note:** The damping coefficient (filter) is divided into 9 levels from 1 to 9. The higher the level, the longer the response time.

Damping coefficient (filtering) table

Damping level	Response time (seconds)
1	12
2	24
3	36
4	48
5	120
6	180
7	240
8	360
9	480

## 2.3.5 Calibration

### 2.3.5.1 Sensor Calibration

Enter the "Calibration" page to start calibration. Manual calibration and automatic calibration can be performed. After the calibration is completed, insert it into the fuel tank and enter "Reading". The page shows that the sensor can accurately read the fuel data in real time, indicating that the calibration is successful.

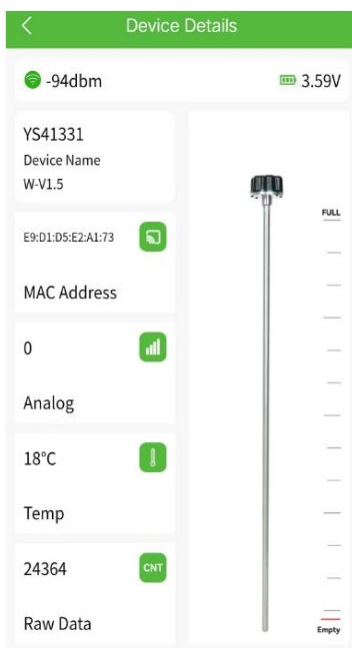
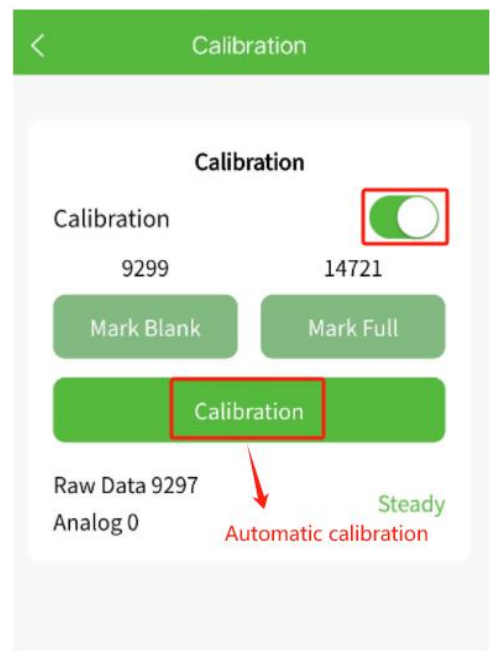
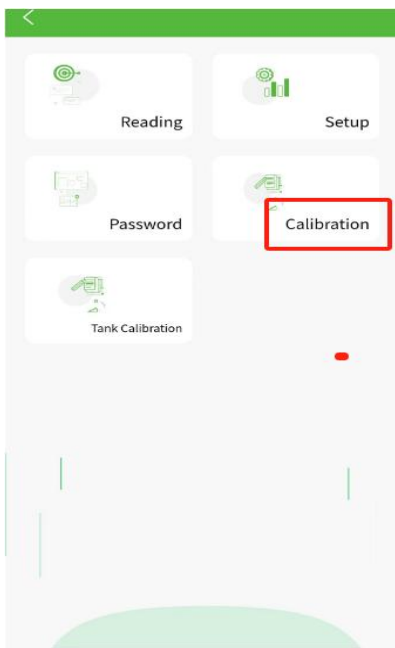

Figure 1

Figure 2

Figure 3

The APP has 2 calibration methods: (manual calibration is more accurate)

**Method 1 – Manual calibration:** Turn off the switch button as shown in Figure 2, first stand the fuel sensor in the air, wait for the data status to display "stable", press the "mark empty" key to mark empty, after the display "calibration successful" put the fuel level sensor into the oil pipe full of oil (the oil in the oil pipe needs to immerse the air outlet on the top of the fuel level sensor), wait for the data status to display "stable", press the "mark full" key to mark full, the above two steps are completed, the next step can be carried out.

**Method 2 – Automatic calibration:** Turn on the switch button as shown in Figure 2, and directly place the fuel level sensor upright in the air. After the data status displays "stable", press the "Confirm Calibration" button, and the calibration is completed when "Calibration Completed" is displayed.

### 2.3.5.2 Fuel tank calibration

Enter the fuel tank calibration interface, manually input the real-time value of the sensor corresponding to the fuel tank level, and export the fuel tank calibration data to calibrate the same type of fuel tank on the platform. Details are shown in the figure below:

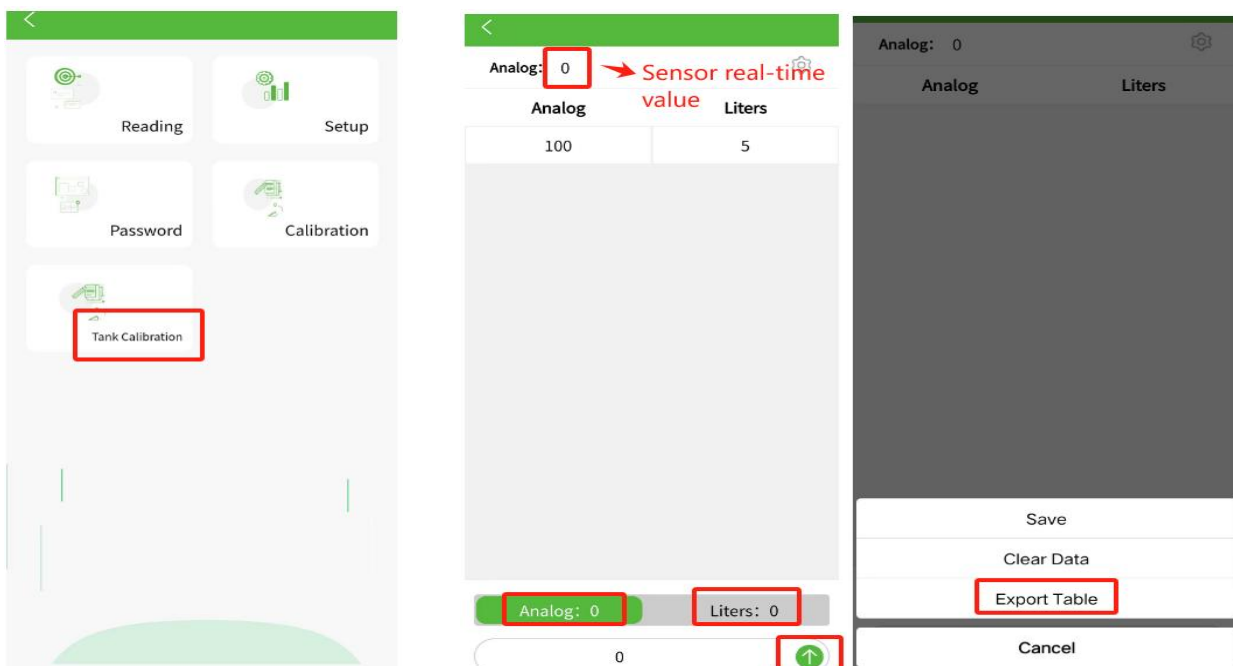

**Note:** For Fuel tanks with different specifications, Fuel tank calibration is required to improve the accuracy of the sensor in real-time monitoring of the fuel level.

## 2.4 Sensor Installation

**Step 1:** The sensor installation position should be in the center of the fuel tank. Use a marker to mark the drilling position. After the position is determined, use a hole opener (35mm) to drill the hole. The position is shown in the figure below:



**Note: 1.** To prevent the cutting iron chips from falling into the oil tank, blow away the iron chips when drilling. The drilling speed should not be too fast. Observe while drilling. When you find that you have reached the bottom of the hole, stop drilling and remove it with needle-nosed pliers (to prevent the iron chips from falling into the oil tank).

**2.** To drill the positioning hole, first clamp the hole opener with a hand drill of more than 35mm, locate the installation position of the hole on the oil tank, and after confirming the position, drill the positioning hole; the hole must avoid obstacles such as internal oil floats, oil return pipes, partitions, etc., and ensure that there are no obstacles within a diameter of about 10cm.

**Step 2:** Before fixing the sensor, check whether the battery cable on the shell is connected and whether the battery cable is pressed by the shell (the battery connector must be inserted into the connection gap) as shown in the figure:

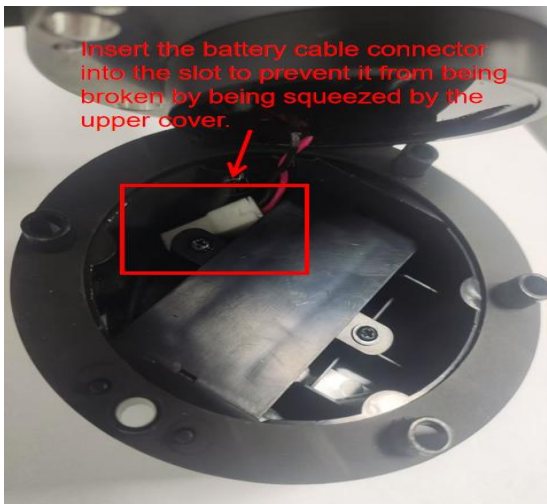

**Step 3:** Check the sensor sealing pad, insert the sensor into the fuel tank with a hole, use dovetail self-tapping screws to drill holes, fix the housing and flange to the fuel tank and lock them.

As shown in the figure:



**Step 4:** After the installation is completed, it will look like the following figure.



## 2.5 Acceptance

Open the mobile phone APP software, connect the sensor( refer to "2.3.2 Sensor Connection" for details). After the sensor is connected normally, enter the sensor details page, select the "Reading" menu to view the data, and the page displays information: device name, analog quantity, sensor temperature, and raw data. You can detect changes in the fuel tank oil level in real time.as shown in the figure below:

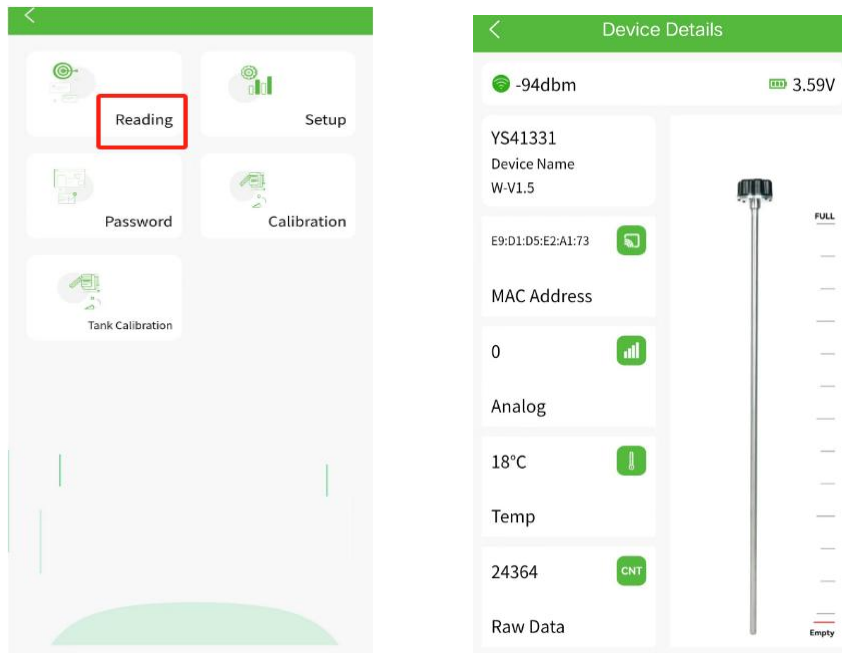

### 3. Common fault description

◆ The APP tool cannot search for the fuel level sensor.

Check whether the Bluetooth of the mobile phone is turned on. If the Bluetooth of the mobile phone is turned on, close the APP and reopen it to try searching and connecting again.

◆ Calibration failed.

When the APP shows that the calibration has failed, check whether the connection status is normal and whether the original value data status at the bottom of the calibration interface is stable. If it is normal, recalibrate.

◆ The liquid level value does not change or the error is large.

Please check whether the air outlet of the fuel level sensor is blocked by foreign matter, or recalibrate the sensor.

### 4. Precautions

- Please make sure that the voltage version of the sensor you purchase matches the power supply voltage, otherwise the sensor will be damaged.
- If you have special requirements for wire or waterproof head specifications,

please contact us for a separate quote.

- Please confirm the sensor communication method with the GPS tracker supplier in advance and ensure that the fuel level sensor is supported.
- If you have a special private agreement, please send it to us in advance for confirmation.
- The sensor only communicates with the GPS tracker. The monitoring platform data is not connected. Please connect with the GPS tracker supplier.
- When installing the fuel level sensor, you need to follow the installation instructions and bring all accessories and corresponding tools.

## 5. After-sales service

- This product enjoys one-year warranty service from the date of shipment.
- If the equipment is damaged due to non-human factors or product quality during the warranty period, please contact us in time for processing.
- We will not repair damage caused by unauthorized dismantling by customers or force majeure (such as floods, vehicle accidents).
- After the warranty period expires, if the product is damaged or malfunctions due to use, the cost of repair materials will be charged.
- Provide customers with free consulting and technical services on product purchase, use, installation, testing, etc.